

# Unlimited Cabinet Door Making Possibilities with Freud's Premier Adjustable Cabinet Door Set

Congratulations on your purchase of Freud's world class Premier Adjustable Cabinet Bit Set. Freud's mission is to design and manufacture the highest quality, most technically advanced cutting tools available. This set contains everything you need to create a variety of beautiful cabinet doors and any other doormaking project you have in mind. Freud develops and manufactures different carbide blends for each cutting application, so you can be sure that the high quality bit you're using was designed specifically for creating flawless raised panel doors in plywood, hardwood and softwood.

This revolutionary set combines Freud's unique patented Premier Adjustable Rail and Stile Router Bit System with a patented four cutter Quadra-Cut™ Raised Panel Bit. The Premier Adjustable Rail and Stile Bit system enables you to build any style of cabinet door in a range of door thicknesses and sizes! The Quadra-Cut™ Raised Panel Bit has two small wings that cut downward and two large wings that shear upward for an extremely smooth cut in hardwoods, softwoods, and even plywood. These extremely easy-to-use solutions give you unlimited creative freedom, and solve the long-standing challenges and limitations of frame and panel door construction.

## Introduction to Door Construction

This unique Premier Adjustable Cabinet Door Set with patented solutions allows woodworkers to build any style of cabinet door in a range of door thicknesses and sizes!

Build a remarkable variety of different styles and sizes of cabinet doors, including:

- Rail and Stile doors with "stub" tenons
- Rail and Stile doors with **extended** tenons for added strength
- Rail and Stile doors with panels of **undersized plywood**
- Double Sided Rail and Stile doors with decorative **profiles on both sides** (requires optional cutters)
- **Glass Panel doors** (requires optional cutters)
- Doors with **thicknesses from 5/8" to 1-1/4"**

### Introduction to Cabinet Door Construction

Cabinet doors may consist of a number of elements. Here are some common terms that will be used throughout these instructions:

**Stiles:** The vertical frame components of the door.

**Rails:** The horizontal frame components of the door.

**Tenon:** An extended piece of wood on the end of a rail that fits into a pocket, or "mortise" in the stile.

**Mortise:** A pocket cut in a stile that matches the tenon on the end of a rail.

**Panel:** The center portion of a door, which is contained within the frame of rails & stiles. Panels may be solid wood (normally a "raised" panel), plywood or glass.

**Glass trim:** The wooden molding which holds glass in the door frame.

Freud produces Quadra-Cut™ Raised Panel Bits (panel cutters) with and without backcutters. Quadra-Cut™ Raised Panel Bits with backcutters are typically used to create doors with panels that are flush with the frame on both sides when using 3/4" stock. Quadra-Cut™ Raised Panel Bits without backcutters are typically used to create doors with panels that sit proud of the frame when using 3/4" stock. Freud also produces Quadra-Cut™ Raised Panel Bits for 5/8" stock for producing panels that are flush with the front of the frame.

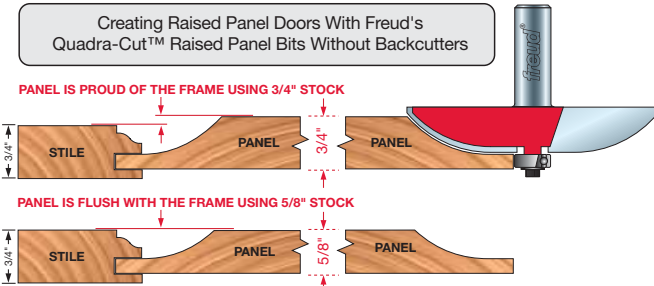
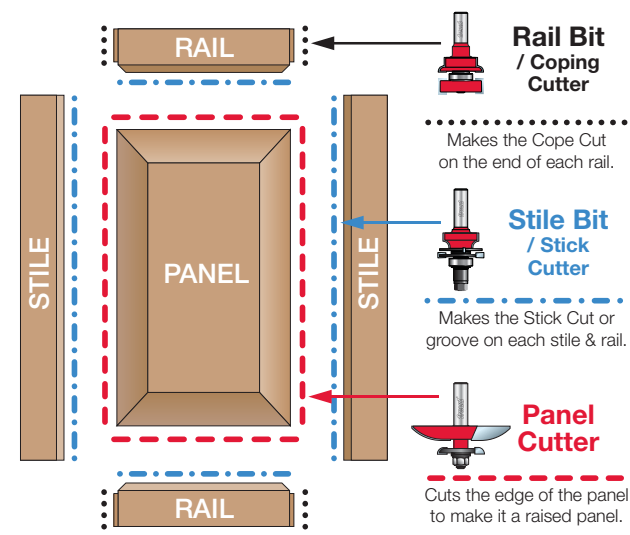

## Tools Required

### Materials Required

In addition to your Freud router bits, you will need the following tools and supplies to build your door unit:

- Variable speed router, 2-1/4 HP minimum. Check your router manual for maximum allowable bit diameter.
- Router table with fence and miter gauge. For best results, use featherboards and push blocks to control work pieces when possible. We also strongly recommend that a shop vacuum or dust collector be used with the router table.
- Table saw for ripping stiles, rails and other door parts.
- For long tenon door construction: Mortising machine, Drill Press with mortising attachment, or Drill Press with brad point bits.
- Various common woodworking hand tools including hammer, chisels, rule, straight edge, square, coping saw.
- Clamps with the capacity to secure all door joints.
- A sturdy, level work table or saw horses for door assembly

## Safety Tips

**WARNING:** Failure to obey these warnings could lead to serious bodily injury or death:

- Use router bits with a router only
- Carbide is a very hard and brittle material. Slight shocks can damage the carbide. Before each use, check that the bit is sharp and free from damage. DO NOT use the bit if it is dull, broken, cracked or if any damage is noticed or suspected
- Before each use, make sure that at least 80% of the router bit shank is inserted into the collet. The end of the bit shank should be at least 1/8" from the bottom of the collet.
- Before each use, ensure that the collet has been tightened and that the work piece is secure.
- Read and obey all warnings and instructions contained in the router's owner's manual, and for any accessory that is used. If you do not have the correct owner's manual, obtain one from the manufacturer before using the router bit.
- Always wear eye protection or a full face shield complying with current ANSI Standard Z87.1
- Always wear hearing protection.
- Keep body, clothing and hair clear of spinning bit. Do not wear loose hanging clothing or jewelry.
- Use a router table and fence wherever possible. Be sure all guards are in place.
- Bits over 1-1/2" in diameter must only be used with the router mounted in the table.
- Use multiple passes when removing large quantities of material.
- Never use bit on router that will exceed maximum recommended RPM of bit.
- If you have any questions regarding your router bits, please call Freud Customer Service at 800-472-7307. In Canada call 800-263-7016.
- Make sure that you are well rested before working with power equipment.
- Do not use power equipment if you have consumed any drugs or alcohol. If you are taking prescription medication, check with your physician to ensure it is safe for you to operate power equipment.
- Always turn off and unplug the router before removing and installing router bits or making adjustments to the router or router accessory.
- Keep these instructions in a safe place for future reference.

## Getting Started: Planning and Preparation

Plan the project carefully before purchasing materials. Refer to the reference below for formulas to calculate the widths and lengths of your stiles, rails, and panel inserts.

Be sure to obtain enough stock to build all doors, plus extra stock for making test cuts. This will make it easier to match the grain and color of the material for a more attractive finish, and milling all stock to thickness at the same time avoids inconsistencies that can affect the quality of your joints. Choose stock with care. Lumber for door construction should be straight, and free from defects such as knots, splits and checks.

### Calculating Sizes of Door Parts

**Stock thickness:** Your Premier Adjustable Stile and Rail bit set is suitable for stock from 5/8" to 1-1/4" thick. To mill double sided or glass panel doors, please contact your Freud Distributor to purchase the optional cutter set to match your profile.

Stile and Rails for common cabinet doors are normally 2" to 2-1/2" wide, depending on your preference and application. Your Freud bits can easily be used to mill stiles and rails of any width.

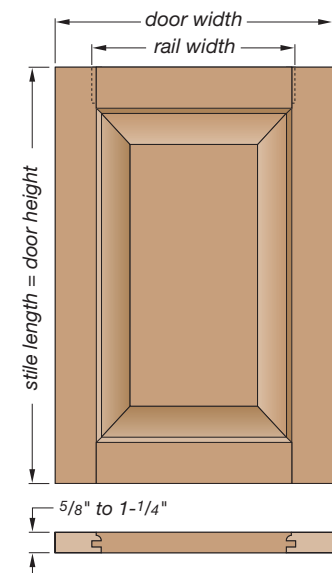

**Rail lengths:** are determined based on the width of the stiles and the length of the tenon you plan to use. The rail length should be equal to: the width of the door, minus the width of two stiles, plus the length of the two stub tenons. A single stub tenon measures 10.3mm (13/32") long, two tenons would be 20.6mm (13/16") long, so the formula is:

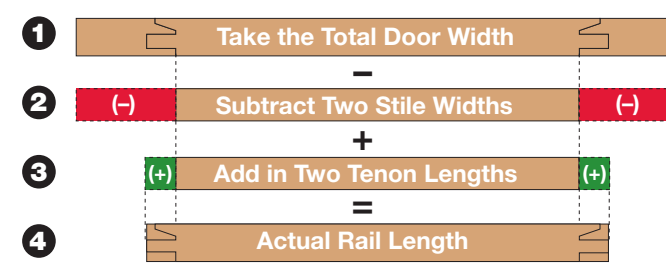

**Door Width - (Stile Width x 2) + 13/16" = Rail length**

**Note:** For doors with extended tenons, add twice the length of the desired tenon.

**Stile lengths:** Should be equal to the finished height of the door.

**Panel Size:** Allow for expansion for wood panels as humidity changes. Panels will expand more across their width (across the grain) than they will along their length (with the grain). Calculate Panel sizes as follows: **Panel width** is equal to the total door width, minus both stile widths, plus the two stub tenon groove depths (13/16"), minus 1/8" for expansion. **Panel length** is equal to the total door height, minus both rail widths, plus the two stub tenon groove depths, minus 1/16" for expansion.

Below is a sample calculation for a single panel door at 12" wide by 18" high using 3/4" stock:

*Note: This calculation is just for example purposes only. You may make a door in a variety of sizes.*

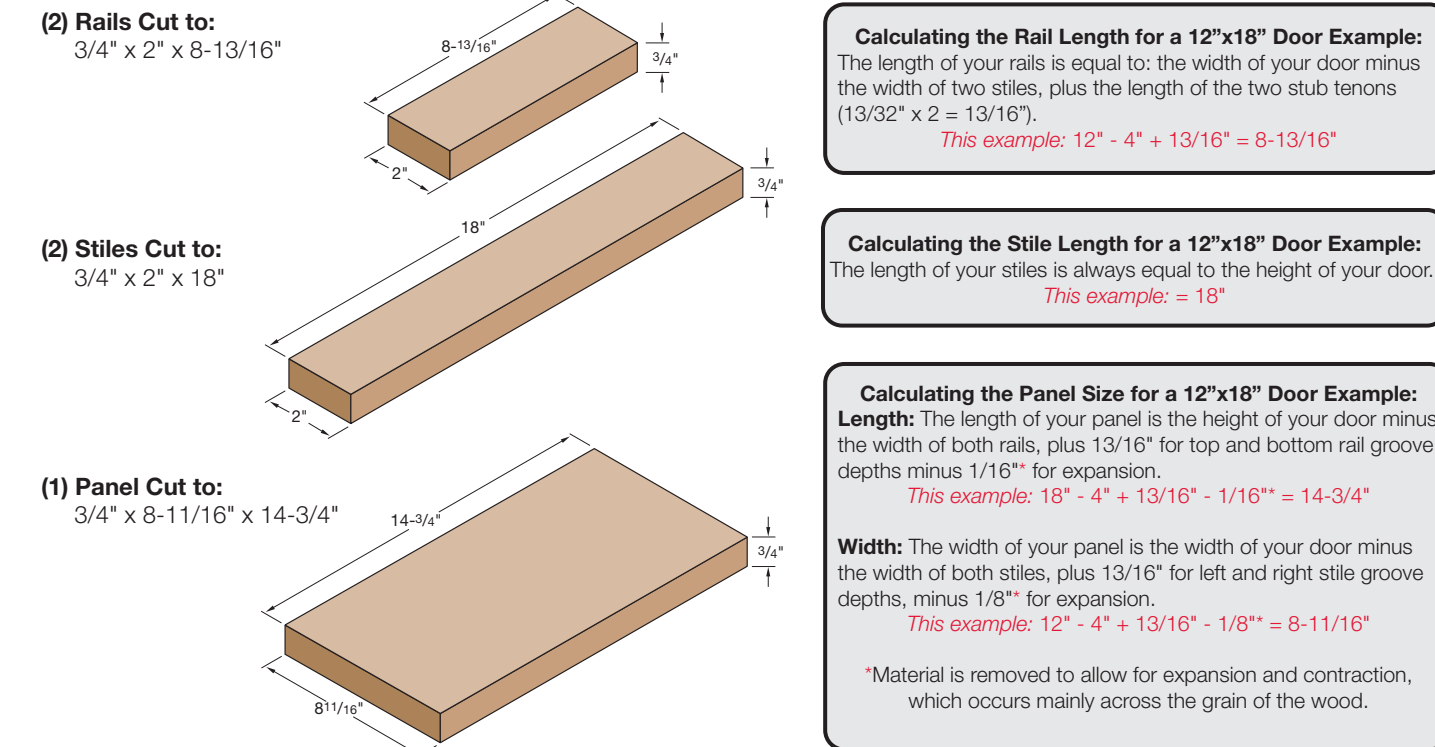

*\*Note: Different species of wood expand and contract differently. To be completely accurate and be sure you remove exactly the right amount, you may want to understand more about the specific wood you are using. There are many wood shrinkage calculators on the internet.*

### Mill and Cut Your Door Parts

a) Read and follow all safety instructions that came with these router bits, as well as your planer, saw and all other tools.

b) Mill all stock to final thickness. If you do not have a thickness planer, many lumber dealers and millwork shops will plane stock for a fee.

c) Rip all stock to finished width. See recommended widths in the previous section. Be sure all edges are perfectly square, and that all surfaces are straight and flat. Freud's LM75 and LM74 series ripping blades are excellent choices for this stock.

d) Cut all parts to length, using the formulas in the previous section. Freud's LU74 and LU85 series Ultimate Cut-Off blades is an excellent choice to ensure a perfect end cut on rail and stile parts.

## Routing the Rails & Stiles

### Doors with (Standard) Stub Tenons.

Your Freud Premier Adjustable Rail and Stile bits come factory-assembled to produce perfectly fit stub tenon joints right out of the box. This is the most common type of cabinet door. It is fast and easy to produce, and gives a beautiful finished appearance.

### Routing Rail Ends:

a) Install the rail bit into the router collet.

b) Set the bit height and make a test cut as follows:

- Set the bit height to produce the desired profile. A common rule is to have the inset "bead" on the face of the stile the same thickness as the "shoulder" on the back of the stile, but this can vary depending on stock thickness and the appearance you desire. In 3/4" thick material, the inset bead should be approximately 1/8" deep.
- Use a straight edge to align the router table infeed and outfeed fences with the bearing on the bit.
- Be sure that the fence is parallel to the miter gauge track.
- Make a test cut across the end of a test piece of stock by using a miter gauge to feed the stock perpendicularly across the cutter (A).

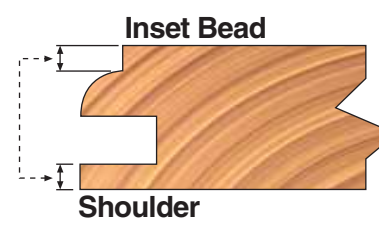

**Tip 1:** Make the opening between the infeed and outfeed fence as narrow as possible (without touching the cutter) to provide maximum support.

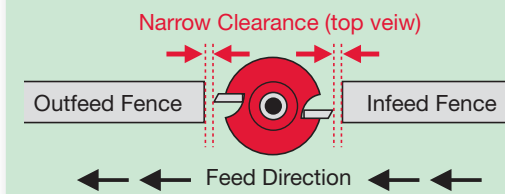

**Tip 2:** Use a backer board, miter gauge, or a sled jig to reduce the chance for blow-out at the back end of the cope cut.

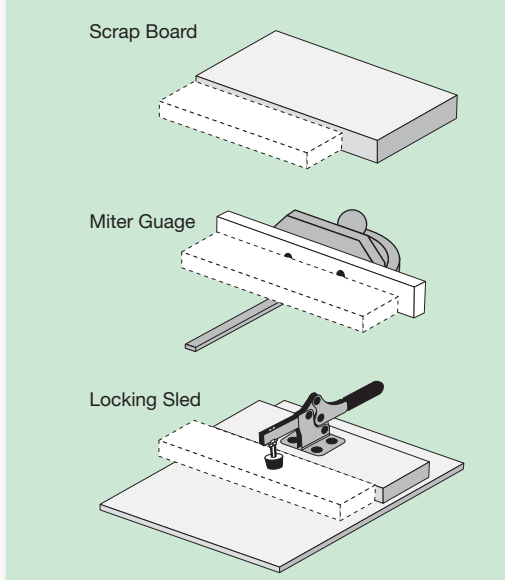

For downloadable plan of the above Locking Coping Sled please visit: [www.freudtools.com](http://www.freudtools.com)

### Routing edges of stiles and rails:

- With the router unplugged, install the stile bit in the router (B). The stile bit is the tallest of the two bits in your set, with one profile cutter and two slot cutters.
- Use a straight edge to align the router table infeed and outfeed fences with the bearing on the bit.
- With the router unplugged, use one of the completed rail (cope) cuts on the end of your rails as a guide to set the cutter height (B).
- Plug the router in and carefully make a test cut in scrap material to check your set up. Use push blocks to control narrow stiles (C).
- Test the fit of your stile sample to the rail ends you routed in the previous step. If you need to adjust the height of the bit, unplug the router, adjust the bit, and make another test cut. Once the height matches perfectly, rout one edge of all stiles and rails.

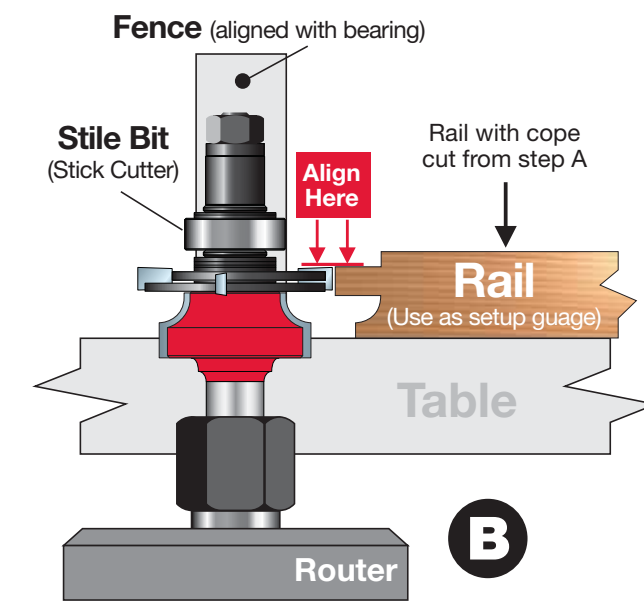

**Tip 1:** Use consistent pressure and feed rate when making the stick cuts. This ensures a consistent and straight groove along the edge of each rail and stile.

**Tip 2:** When making the stile (stick) cuts, use feather boards to hold the material safely on the table and use push sticks for safety.

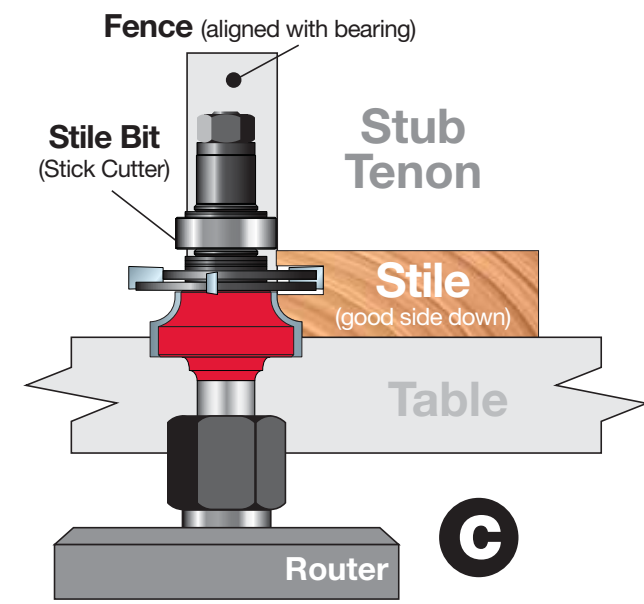
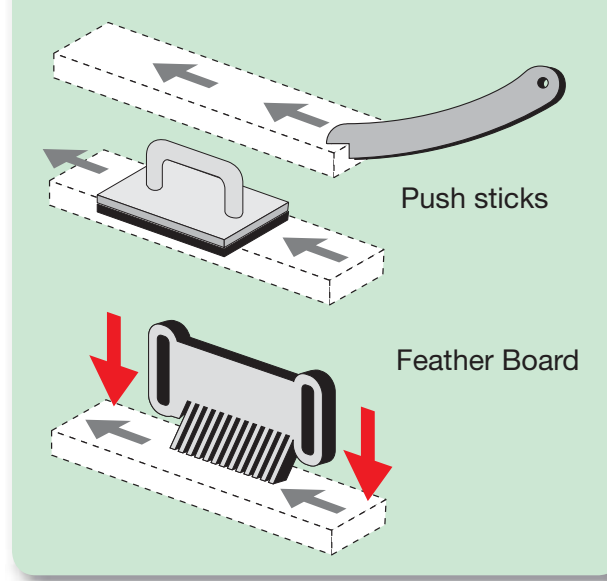

### Routing rail ends with extended tenons:

For stronger joints in your cabinet doors, your Freud set offers a unique capability to mill tenons of unlimited length. This capability is especially important for large or heavy doors, and doors that will be subjected to excessive use and stress:

- First, calculate the length of your tenons. As a general rule, plan on your long tenons being as long as half the width of your stiles. For example, if your stile width is 2-1/2", then a 1-1/4" long tenon will be a good choice.
- Be sure that the fence is parallel to the miter gauge track, then rout across each rail end using the same procedure described for routing the stub tenons (A). For this first cut, leave the rail bit fully assembled with the bearing and upper cutter in place. This will produce a stub tenon.

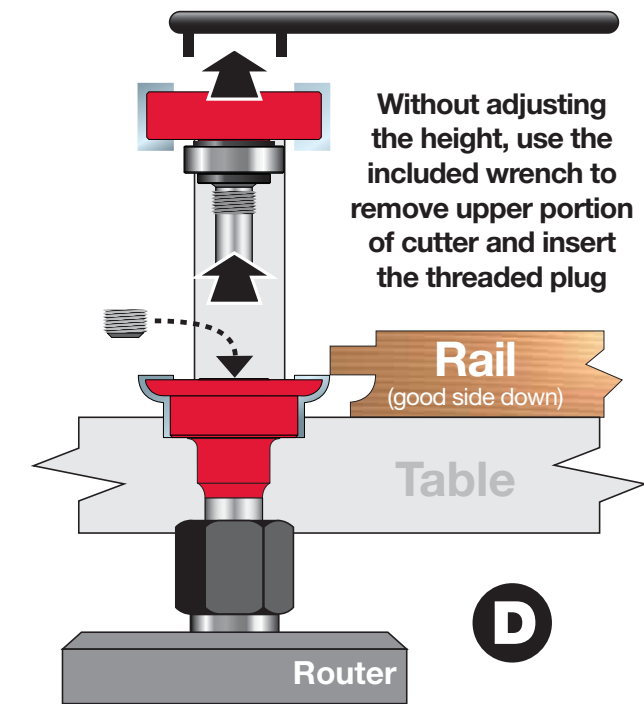

- Now, unplug the router. Using the supplied spanner wrench, turn the bit counterclockwise and remove the upper portion of the cutter as shown (D). Use the router spindle lock or your router wrench to prevent the bit from turning. DO NOT change the height of the bit!

- Insert the threaded plug supplied with your set into the threaded hole in the rail bit. Tighten securely with a 3/16" or 5mm Allen wrench (not supplied).

- Second pass: Long tenons should be routed in multiple passes (E). Move the fence back 1/2" from the position used for the first pass. Use a miter gauge, and with the good or "face" side of the rails facing down; make the rail end cut on one side of each end of all rail parts that are to have long tenons. ROUT ONLY the face side of the rail!
- Move the fence back in increments of not more than 1/2" and repeat the procedure described for the second pass. Continue this process until the tenon reaches the desired length on the face side.

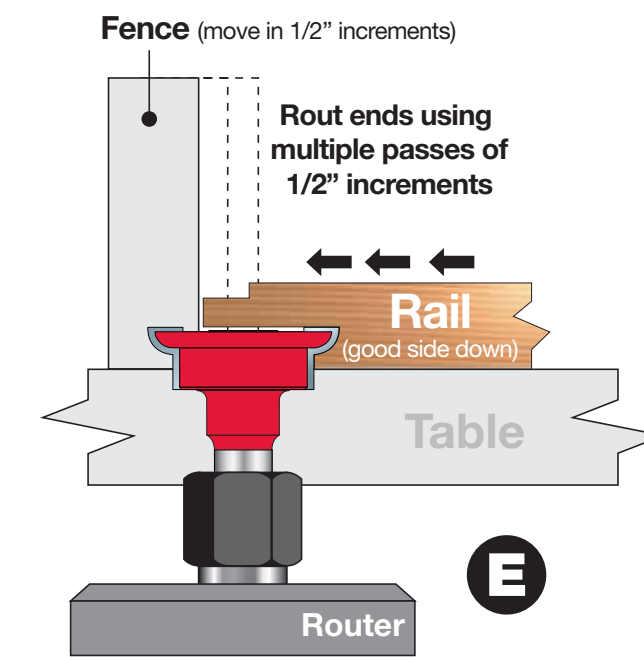

- Unplug the router, remove the threaded plug and carefully thread the spindle containing the bearing and upper cutter back into the rail bit. Tighten with the spanner wrench (F). DO NOT change the position of the fence!

- Lower the router and bit (G). Turn your rail face up, and use the stub tenon you routed to adjust the bit height. The top of the cutter should be lower than the underside of the stub tenon for the first pass. **Important Note:** The first pass to remove stock from the back of the tenon should be made with the bit raised no more than 1/8" above the table. If more stock must be removed to finish the tenon (this may be the case if your rails are more than 3/4" thick), make these cuts in multiple passes, raising the bit no more than 1/8" per cut. On the final pass, the top of the rail bit should precisely match the underside of the stub tenon. This will create a long tenon and profile that will perfectly match the stile profile. **Note:** For an alternative method for step G, please see the enclosed video.

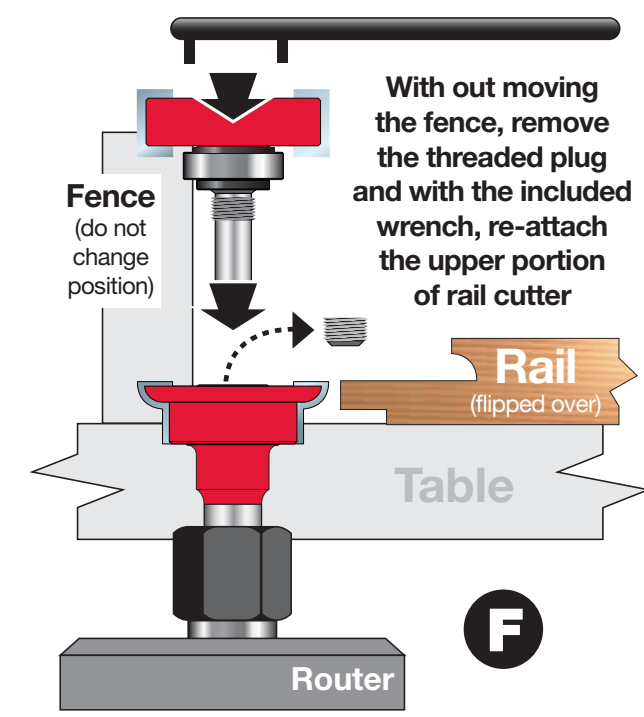
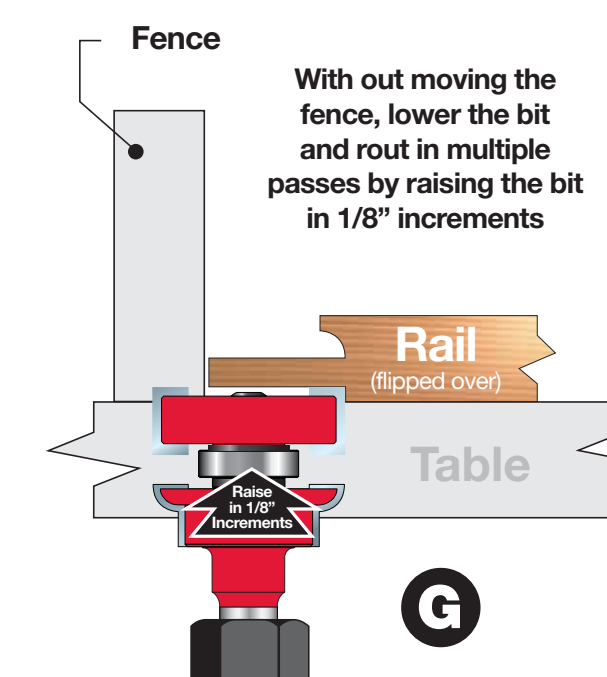

**freud**  
Precisely the best.  
[www.freudtools.com](http://www.freudtools.com)



## Finish the Mortise and Tenon Joints:

a) First, carefully "haunch" the tenons as shown in the photo. This step produces a stronger and more attractive joint and conceals the tenon within the end of the stile. Cut the haunched tenon with a band saw, jig saw or handsaw.

b) Lay out and cut mortises in the door stiles to accept the tenons. The tenon should fit snugly into the mortise. There are several ways to cut mortises:

- The easiest method is to use a mortiser or drill press mortising attachment.
- If you don't have a mortiser or mortising machine, an alternative technique is to use a brad point bit or forstner bit in a drill press to remove most of the stock for the mortise, and then use a chisel to remove the remaining stock and to "square up" the mortise. Drill only about 1/16" deeper than required for the tenon.

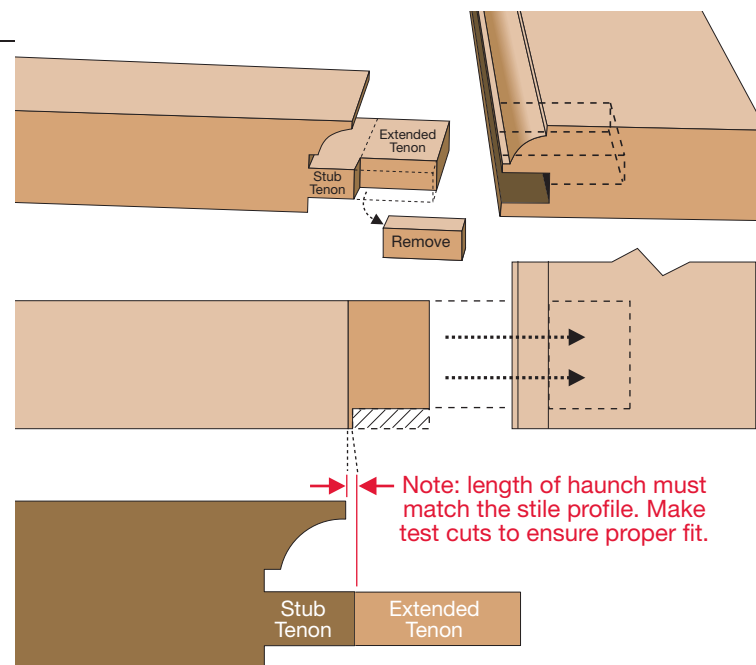

## Making Adjustments for Plywood Panel Doors

### Plywood Panels

Adjusting the bits for thinner grooves for rattle free plywood panels: If you want to make doors with plywood panels, your bits can be adjusted to produce grooves as thin as 5.5mm. This is important, because most 1/4" plywood is actually much thinner than a true 1/4".

- To adjust the groove width produced by the stile bit, unplug the router and install the bit in the collet. Use a 1/2" open end wrench or adjustable wrench (not included) to remove the nut on top of the spindle. Carefully unstack the components of the bits until you remove the upper of the two slot cutters. You will find thin shims between these cutters. Removing some of these shims will produce a narrower groove. Adding shims from the extras stored under the nut will make the groove thicker. Reassemble the bit, secure the nut, and make tests cuts to check your adjustment.

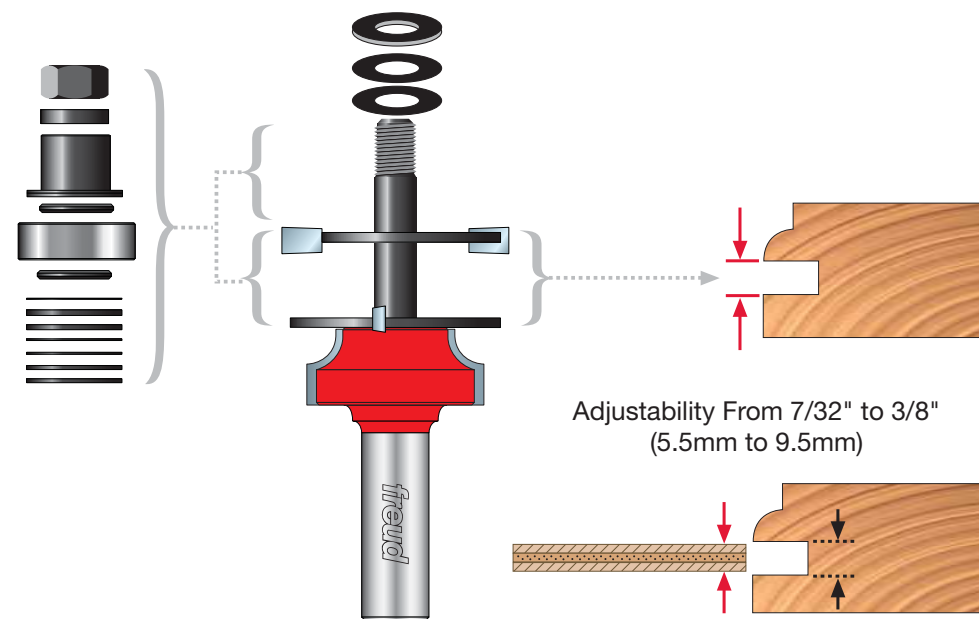

- To adjust the thickness of the tongue, unplug the router and install the rail bit. Use the supplied Allen wrench to loosen the screw and remove the top cutter.

- To make the tongue thinner, remove some of the shims you will find on top of the bearing. To make the tongue thicker, add shims in this area from the collection of extra shims you will find in the package containing the wrenches. Reassemble the bit, secure the screw, and make test cuts to check your adjustment.

## Routing Raised Panel Doors

### Creating the Raised Panel:

#### Installing the raised panel cutter.

- Unplug the router.
- Be sure the collet of the router is clean and in good working order.
- Make sure that 80% or more of the router bit shank is inserted in the router collet.
- Set the router speed to the recommended setting for the cutter.
- Tighten the bit securely in the collet.

#### Setting the cutter height and making a test cut.

- For a raised panel cutter with a back cutter, with the router unplugged, set the cutter height so the tongue of the cope cut on your rails is aligned with the gap between the back cutter and the panel cutter (H).

- For a raised panel cutter without a back cutter, with the router unplugged, set the cutter height so the remaining tongue thickness on the panel is 15/64".

- Set the fence depth forward so that the cutter will remove 1/3 of the material. Before plugging the router in be sure that the bit rotates freely and does not contact any part of the router, the router table or the router fence. Plug in the router and make a cut on one edge of the test panel.

- Unplug the router.

- Set the fence depth back so that the cutter will remove the next 1/3 of the material. Before plugging the router in be sure that the bit rotates freely and does not contact any part of the router, the router table or the router fence. Plug in the router and make a cut pass on the cutter.

- Unplug the router.

- Set the fence so that it is aligned with the bearing on the cutter. Before plugging the router in, be sure that the bit rotates freely and does not contact any part of the router, the router table or the router fence. Plug in the router and make a cut pass to remove the final portion of the material.

#### Fine Tuning the Cutter Height.

- Unplug the router.
- Fit the test panel into the rail and stile parts to ensure that the panel will fit snugly into the groove.
- Adjust the cutter height and repeat the above test cut steps if necessary.

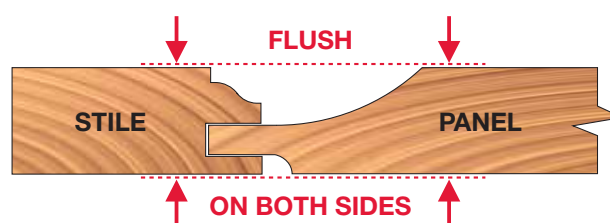

#### Making the Raised Panel Cuts.

- Unplug the router.
- Reset the fence to remove 1/3 of the material from the panel.
- Before plugging in the router be sure that the bit rotates freely and does not contact any part of the router, the router table or the router fence. Plug in the router and make a cut along the end grain of the panel.
- Rotate the panel 1/4 turn counter-clockwise and make a cut with the grain.

- Rotate the panel 1/4 turn counter-clockwise and make a cut along the end grain of the panel.

- Rotate the panel 1/4 turn counter-clockwise and make the final cut on the panel.

- Unplug the router.

- Reset the fence to remove the next 1/3 of the material from the panel. Before plugging the router in be sure that the bit rotates freely and does not contact any part of the router, the router table or the router fence. Plug in the router and make four additional passes in counter-clockwise sequence as above.

- Unplug the router.

- Set the fence so that it is aligned with the bearing on the cutter. Before plugging the router in be sure that the bit rotates freely and does not contact any part of the router, the router table or the router fence. Plug in the router and make the final four passes in a counter-clockwise sequence.

### Assembling and Finishing the Door

#### Dry Fitting the Door Parts.

- Assemble all of the parts of the door and verify that the final door size is correct.

- If you cut your rails and stiles wider than your finished width, rip them down to the correct size on your table saw.

**Tip 1:** Use a Freud LM74 or LM75 series Glue Line Rip blade on your table saw to create a perfect finished edge on the rails and stiles.

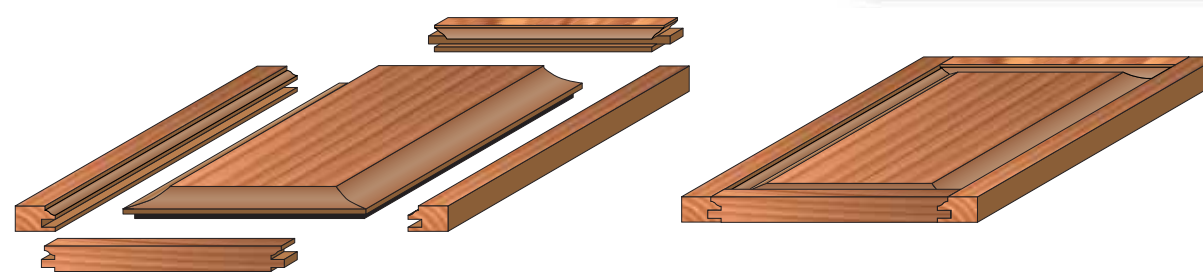

#### Pre-Finishing the Door Parts.

- Apply finish to the raised panel before assembling the door to ensure consistent coverage where the edge of the raised panel tucks into the grooves of the rails and stiles.

- Do not apply finish to the cope cuts on the rails or the stick cuts at the end of the stiles, as this will weaken the glue joints on the finished door.

#### Glueing and Assembling the Door Parts.

- Glue and clamp the cope cuts at the end of the rails into the stick cuts on the stiles.

- Do not glue the raised panel to the rails and stiles. The panel is intended to "float" inside the rail and stile frame to allow expansion and contraction of the wood, due to heat and humidity.

## Making Large Glued Door Panels

### Optional Glue Joining Instructions for Making Large Panels

When making wider panels, you'll want to make a glue joint for a superior fit and secure door. Using Freud's 99-038 Raised Panel "V" Joint Bit or the 99-031 Reversible Glue Joint Bit, you can make stronger joints by creating a larger surface area for glue. These bits are ideal for joining narrow boards to form wide panels such as what is required for larger raised panel doors. The joint produced aligns the pieces and provides more glue surface for a strong, invisible joint.

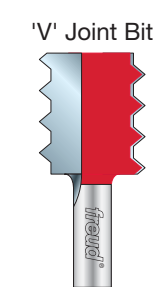

Item # 99-038

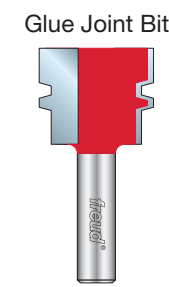

Item # 99-031

#### Insert the Glue Joint Bit Into the Router Collet.

- The Glue Joint Bit should only be used in a table mounted router.

- Unplug the router.

- Be sure the collet of the router is clean and in good working order.

- Set the router speed to the recommended setting for the cutter.

- Make sure that 80% or more of the router bit shank is inserted in the router collet.

- Tighten the bit securely in the collet.

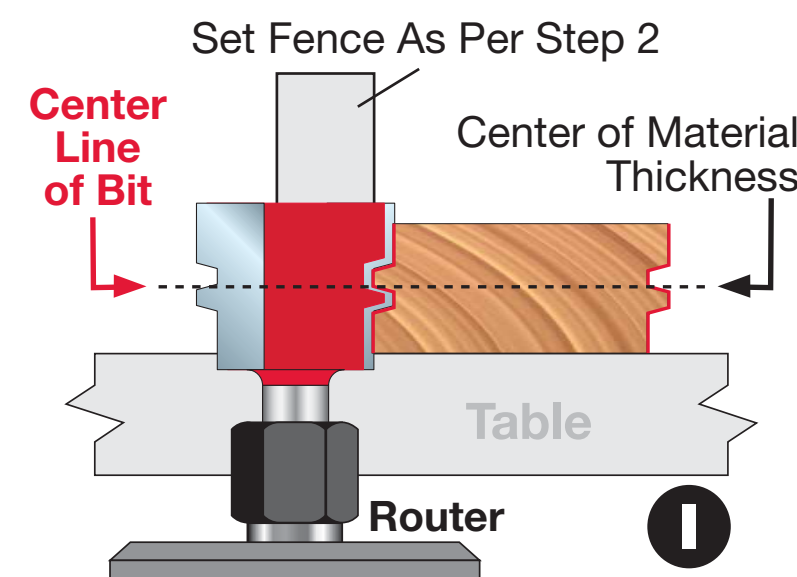

**Tip 1:** For best results, plane all material to consistent thickness and joint the edges before using the Glue Joint Bit.

**Tip 2:** When making the cuts use feather boards, hold down and use push sticks for safety and best results.

**Tip 3:** A router table fence with separately adjustable infeed and outfeed fence faces such as the Freud SH-5 provides the capability to use the Glue Joint Bit to straighten and flatten imperfect board edges and eliminates the need to use a jointer.

#### Set the Cutter Height and Make a Test Cut.

- Unplug the router.

- The height of the cutter above the router table must be equal to half the material thickness plus 5/8".

- Use a straight edge to set the router table infeed and outfeed fences to be aligned with the smallest cutting diameter of the bit, as shown in the illustration in step 1.

- Before plugging the router in be sure that the bit rotates freely and does not contact any part of the router, the router table or the router fence. Plug in the router and make a cut along the edge of a piece of sample stock.

- Cut the sample piece in half and flip one of the cut pieces. Check the fit of the joint.

- Unplug the router.

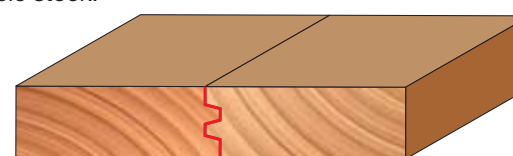

- Adjust the cutter height if necessary to make the surfaces flush. If the piece that was flipped is higher than the piece that is face up you need to lower the bit. If the flipped piece is lower you need to raise the bit.

- Before plugging the router in be sure that the bit rotates freely and does not contact any part of the router, the router table or the router fence. Plug in the router and make another test cut.

### Create Glue Joint Edges

- Label the best surface of each board as "Face"
- Run one edge of a board with the side labeled "Face" up
- Flip the board and run the opposite edge with the "Face" down.

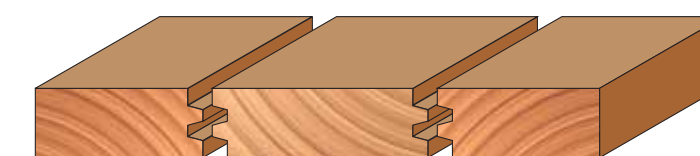

- Repeat these steps on all but two of the pieces.

- One of the remaining two pieces should be run "Face" side up on one edge only.

- The last should piece be run with the "Face" side down on one edge only.

### Glue and Clamp the Panel

- Turn all of the pieces face side up.

- Arrange the pieces so that the mating edges are adjacent and the board on each end has a flat edge.

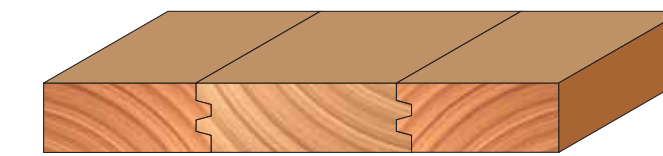

- Apply glue to all edges and use plenty of clamps to secure the panel until the glue dries.

- Remove the clamps, sand or plane the panel flat and smooth and trim to final size.

## Optional Add-On Cutters for Expanded Possibilities

### Add-On Double Sided Profile Cutters

#### Rail Bit Adjustment for Double Sided Doors (K):

- With the router unplugged, install the rail bit in the router.

- Use the spanner wrench (supplied) to remove the upper cutter, bearing and spindle assembly. Store this assembly safely for future use.

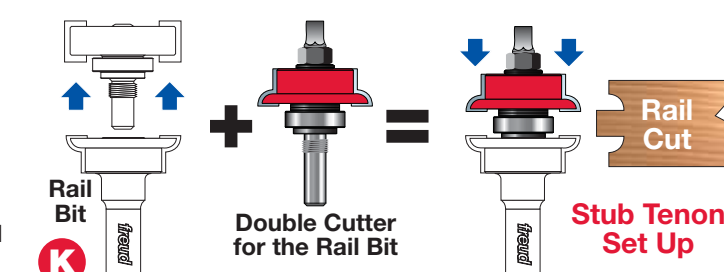

- Carefully thread the Long Spindle, Bearing and Cutter into the lower portion of the bit. Tighten this spindle using a closed end or adjustable wrench (not included).

- Use the bearing to position the fence. Adjust the height of the bit so the stub tenon will be centered in the rail.

- Plug the router in, make test cuts in scrap stock to check the bit height. Unplug and adjust the bit if needed.

- Use a backer board, miter gauge, or a coping sled to rout the rail profile with stub tenon on the ends of all rails.

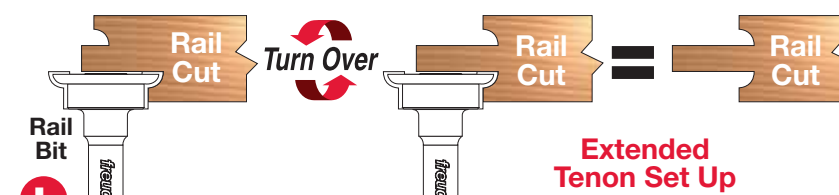

**NOTE:** to produce extended tenons (L), first refer to the instructions for your Premier Adjustable Rail & Stile set, then review these additional procedures. Use your closed end or adjustable wrench to remove the spindle/bearing/cutter assembly. Make cuts with the lower cutter in increments of not more than 1/2". Make cuts with the rail face down first, then turn the rail over and make an identical cut on the back side. In this way the decorative profile will appear on both sides, and the long tenon will be perfectly centered. (Note: the straight cutter supplied with the rail bit is not used in this operation, because the decorative profile is used on both sides of the rail)

#### Stile Bit Adjustment (M):

- With the router unplugged, install the stile bit in the router.

- Use your 1/2" open end or adjustable wrench to remove the nut from the spindle.

- Carefully remove extra shims, bearing, and the small spacer between the bearing and the upper slot cutter.

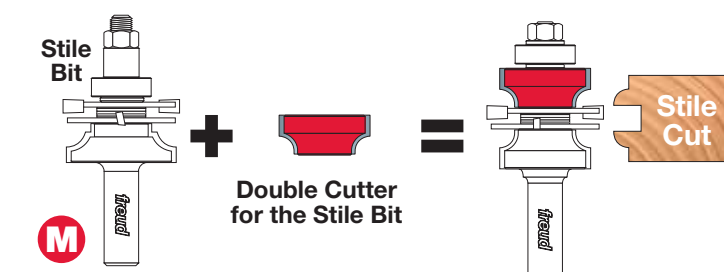

- Place the Profile Cutter on the bit. BE SURE that you have selected the cutter for the stile bit – the cutting edge must face in the same direction as the lower profile cutter!

- Place the bearing on top of the upper cutter, place at least one shim on top of the bearing, replace the nut and tighten.

- Do not use the 7/16" long spacer – store it safely for future use.

- Use the bearing to align the fence. NOTE: in this application the bearing is for fence alignment purposes only. Your workpiece will not touch the bearing. Like all operations with this set, a router table fence must be used.

- Adjust the height of the bit to match the tenons routed with the stile bit. Plug the router in, and make test cuts in scrap material to check the fit.

### Add-On Glass/Screen Panel Cutter

#### Stile Bit Adjustment with Glass/Screen Cutter (N):

- With the router unplugged, install the stile bit in the router. Use your 1/2" open end or adjustable wrench to remove the nut from the spindle.

- Carefully remove extra shims and bearing. Leave the 1.5mm (.06") thick spacer on the top of the upper slot cutter.

- Place the Straight Cutter on the bit. BE SURE that the cutting edge faces in the same direction as the lower cutter!

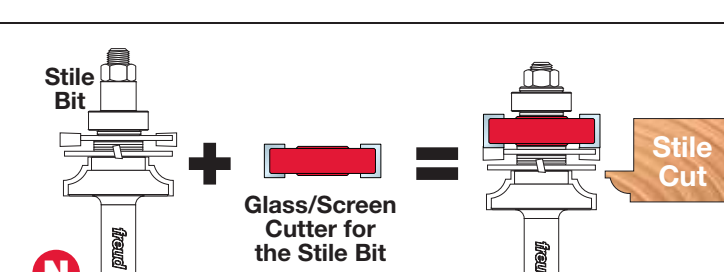

- Place a shim on top of the straight cutter, then replace the bearing, extra shims and nut. Secure the nut.

- Do not use the 7/16" long spacer – store it safely for future use.

- Use the bearing to align the fence. NOTE: in this application the bearing is for fence alignment purposes only. Your workpiece will not touch the bearing. Like all operations with this set, a router table fence must be used.

- Adjust the height of the bit to match the profile routed with the stile bit. Plug the router in, and make test cuts in scrap material to check the fit.

- Due to the large amount of stock removed, make this cut in 2 or more passes.

**Just Some of the Other Great Door Making Sets Offered by Freud:**



French Door Making Sets



Interior and Exterior Door Making Sets

To learn more, please visit:  
[www.mcfelys.com](http://www.mcfelys.com)  
1-800-443-7937

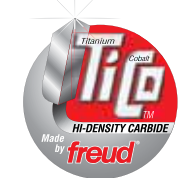

**freud**  
Precisely the best.



### Finish the Mortise and Tenon Joints:

a) First, carefully "haunch" the tenons as shown in the photo. This step produces a stronger and more attractive joint and conceals the tenon within the end of the stile. Cut the haunched tenon with a band saw, jig saw or handsaw.

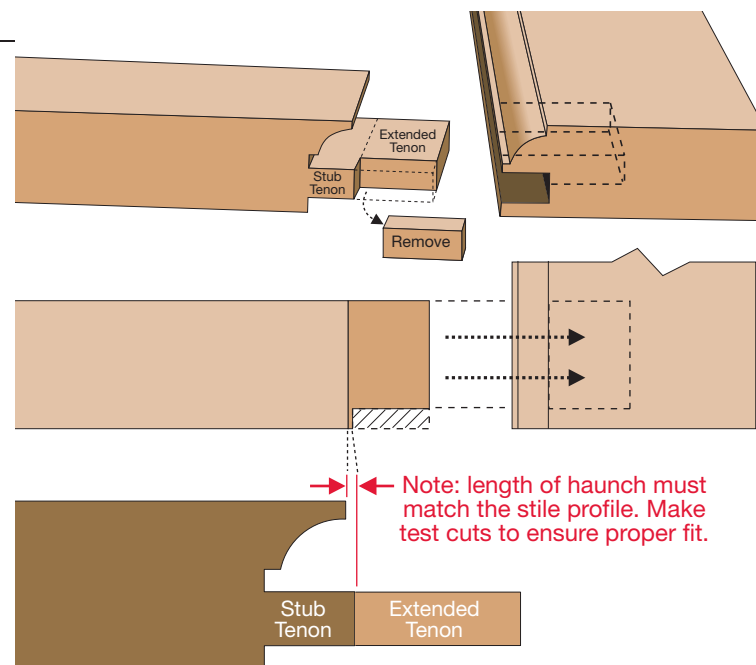

b) Lay out and cut mortises in the door stiles to accept the tenons. The tenon should fit snugly into the mortise. There are several ways to cut mortises:

- The easiest method is to use a mortiser or drill press mortising attachment.
- If you don't have a mortiser or mortising machine, an alternative technique is to use a brad point bit or forstner bit in a drill press to remove most of the stock for the mortise, and then use a chisel to remove the remaining stock and to "square up" the mortise. Drill only about 1/16" deeper than required for the tenon.

Note: length of haunch must match the stile profile. Make test cuts to ensure proper fit.

### Making Adjustments for Plywood Panel Doors

#### Plywood Panels

Adjusting the bits for thinner grooves for rattle free plywood panels:  
If you want to make doors with plywood panels, your bits can be adjusted to produce grooves as thin as 5.5mm. This is important, because most 1/4" plywood is actually much thinner than a true 1/4".

- To adjust the groove width produced by the stile bit, unplug the router and install the bit in the collet. Use a 1/2" open end wrench or adjustable wrench (not included) to remove the nut on top of the spindle. Carefully unstack the components of the bits until you remove the upper of the two slot cutters. You will find thin shims between these cutters. Removing some of these shims will produce a narrower groove. Adding shims from the extras stored under the nut will make the groove thicker. Reassemble the bit, secure the nut, and make tests cuts to check your adjustment.

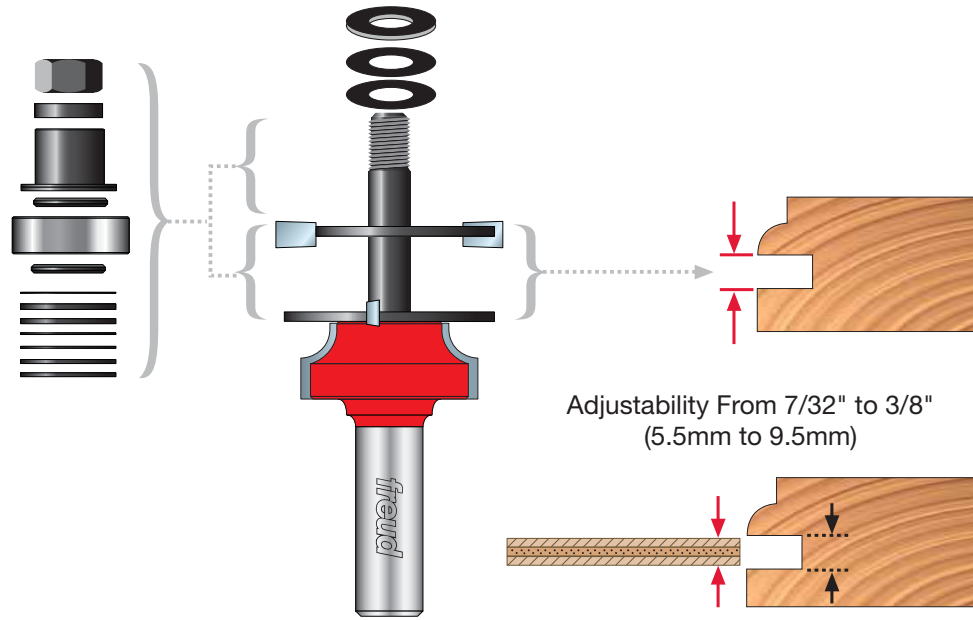

- To adjust the thickness of the tongue, unplug the router and install the rail bit. Use the supplied Allen wrench to loosen the screw and remove the top cutter.

- To make the tongue thinner, remove some of the shims you will find on top of the bearing. To make the tongue thicker, add shims in this area from the collection of extra shims you will find in the package containing the wrenches. Reassemble the bit, secure the screw, and make test cuts to check your adjustment.

### Routing Raised Panel Doors

#### Creating the Raised Panel:

##### Installing the raised panel cutter.

- Unplug the router.
- Be sure the collet of the router is clean and in good working order.
- Make sure that 80% or more of the router bit shank is inserted in the router collet.
- Set the router speed to the recommended setting for the cutter.
- Tighten the bit securely in the collet.

##### Setting the cutter height and making a test cut.

- For a raised panel cutter with a back cutter, with the router unplugged, set the cutter height so the tongue of the cope cut on your rails is aligned with the gap between the back cutter and the panel cutter (H).

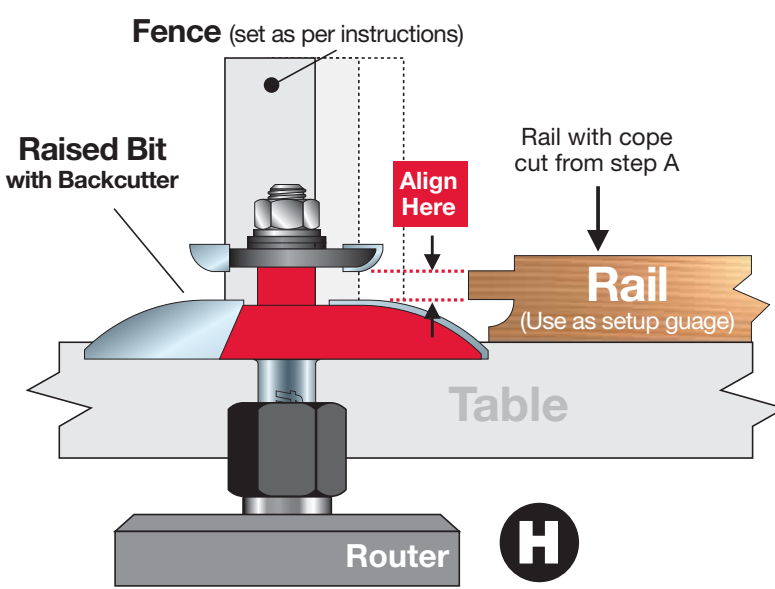

- For a raised panel cutter without a back cutter, with the router unplugged, set the cutter height so the remaining tongue thickness on the panel is 15/64".

- Set the fence depth forward so that the cutter will remove 1/3 of the material. Before plugging the router in be sure that the bit rotates freely and does not contact any part of the router, the router table or the router fence. Plug in the router and make a cut on one edge of the test panel.
- Unplug the router.
- Set the fence depth back so that the cutter will remove the next 1/3 of the material. Before plugging the router in be sure that the bit rotates freely and does not contact any part of the router, the router table or the router fence. Plug in the router and make a cut pass on the cutter.

- Unplug the router.
- Set the fence so that it is aligned with the bearing on the cutter. Before plugging the router in, be sure that the bit rotates freely and does not contact any part of the router, the router table or the router fence. Plug in the router and make a cut pass to remove the final portion of the material.

##### Fine Tuning the Cutter Height.

- Unplug the router.
- Fit the test panel into the rail and stile parts to ensure that the panel will fit snugly into the groove.
- Adjust the cutter height and repeat the above test cut steps if necessary.

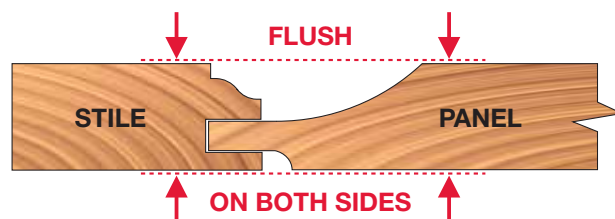

##### Making the Raised Panel Cuts.

- Unplug the router.
- Reset the fence to remove 1/3 of the material from the panel.
- Before plugging in the router be sure that the bit rotates freely and does not contact any part of the router, the router table or the router fence. Plug in the router and make a cut along the end grain of the panel.
- Rotate the panel 1/4 turn counter-clockwise and make a cut with the grain.

- Rotate the panel 1/4 turn counter-clockwise and make a cut along the end grain of the panel.
- Rotate the panel 1/4 turn counter-clockwise and make the final cut on the panel.
- Unplug the router.
- Reset the fence to remove the next 1/3 of the material from the panel. Before plugging the router in be sure that the bit rotates freely and does not contact any part of the router, the router table or the router fence. Plug in the router and make four additional passes in counter-clockwise sequence as above.
- Unplug the router.
- Set the fence so that it is aligned with the bearing on the cutter. Before plugging the router in be sure that the bit rotates freely and does not contact any part of the router, the router table or the router fence. Plug in the router and make the final four passes in a counter-clockwise sequence.

### Assembling and Finishing the Door

#### Dry Fitting the Door Parts.

- Assemble all of the parts of the door and verify that the final door size is correct.

- If you cut your rails and stiles wider than your finished width, rip them down to the correct size on your table saw.

**Tip 1:** Use a Freud LM74 or LM75 series Glue Line Rip blade on your table saw to create a perfect finished edge on the rails and stiles.

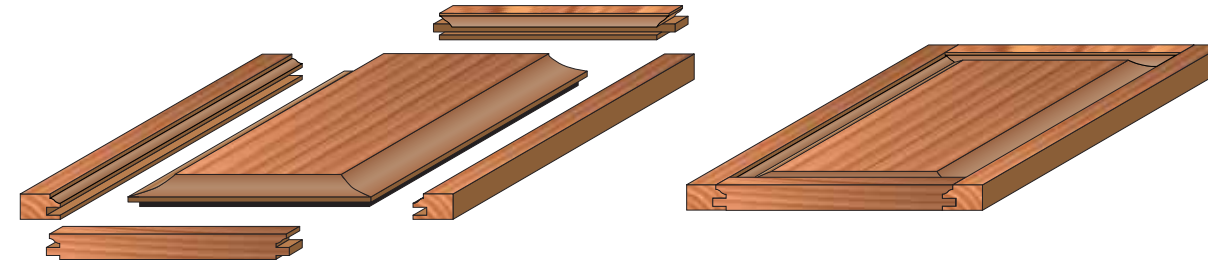

#### Pre-Finishing the Door Parts.

- Apply finish to the raised panel before assembling the door to ensure consistent coverage where the edge of the raised panel tucks into the grooves of the rails and stiles.
- Do not apply finish to the cope cuts on the rails or the stick cuts at the end of the stiles, as this will weaken the glue joints on the finished door.

#### Glueing and Assembling the Door Parts.

- Glue and clamp the cope cuts at the end of the rails into the stick cuts on the stiles.
- Do not glue the raised panel to the rails and stiles. The panel is intended to 'float' inside the rail and stile frame to allow expansion and contraction of the wood, due to heat and humidity.

### Making Large Glued Door Panels

#### Optional Glue Joining Instructions for Making Large Panels

When making wider panels, you'll want to make a glue joint for a superior fit and secure door. Using Freud's 99-038 Raised Panel "V" Joint Bit or the 99-031 Reversible Glue Joint Bit, you can make stronger joints by creating a larger surface area for glue. These bits are ideal for joining narrow boards to form wide panels such as what is required for larger raised panel doors. The joint produced aligns the pieces and provides more glue surface for a strong, invisible joint.

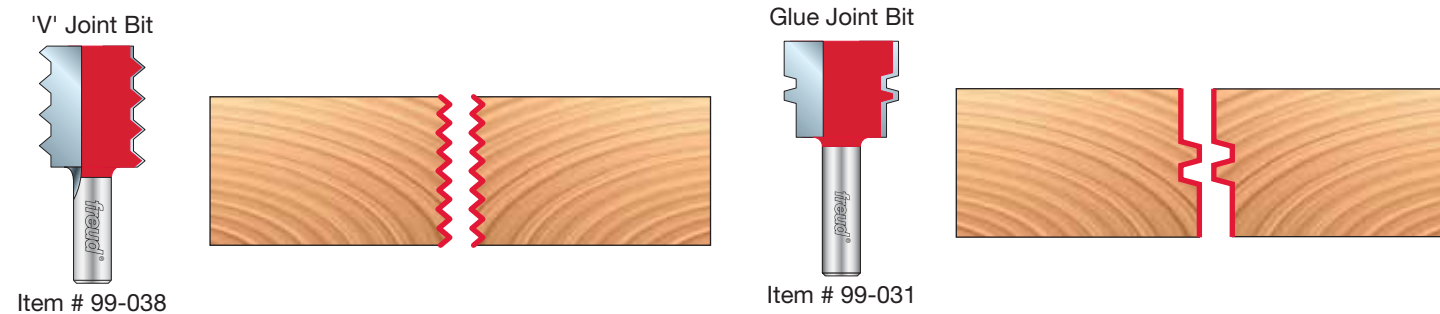

#### Insert the Glue Joint Bit Into the Router Collet.

- The Glue Joint Bit should only be used in a table mounted router.
- Unplug the router.
- Be sure the collet of the router is clean and in good working order.
- Set the router speed to the recommended setting for the cutter.
- Make sure that 80% or more of the router bit shank is inserted in the router collet.
- Tighten the bit securely in the collet.

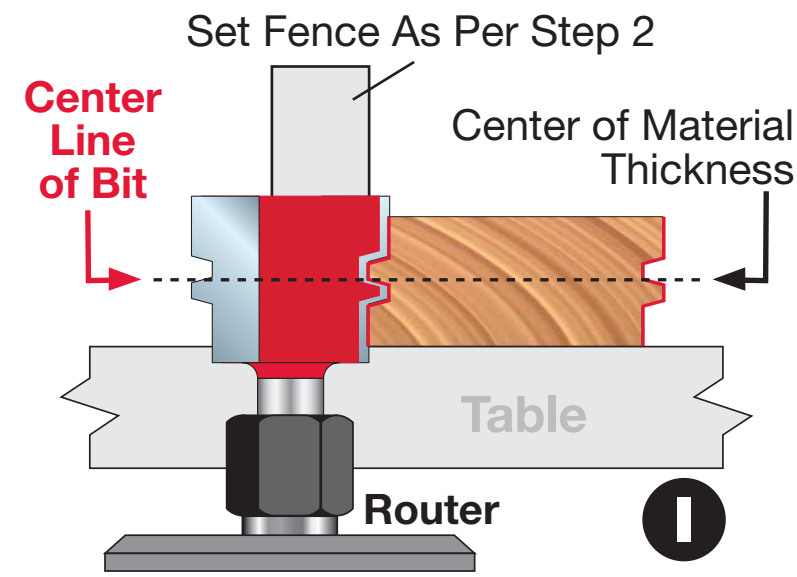

**Tip 1:** For best results, plane all material to consistent thickness and joint the edges before using the Glue Joint Bit.

**Tip 2:** When making the cuts use feather boards, hold down and use push sticks for safety and best results.

**Tip 3:** A router table fence with separately adjustable infeed and outfeed fence faces such as the Freud SH-5 provides the capability to use the Glue Joint Bit to straighten and flatten imperfect board edges and eliminates the need to use a jointer.

#### Set the Cutter Height and Make a Test Cut.

- Unplug the router.
- The height of the cutter above the router table must be equal to half the material thickness plus 5/8".
- Use a straight edge to set the router table infeed and outfeed fences to be aligned with the smallest cutting diameter of the bit, as shown in the illustration in step 1.
- Before plugging the router in be sure that the bit rotates freely and does not contact any part of the router, the router table or the router fence. Plug in the router and make a cut along the edge of a piece of sample stock.
- Cut the sample piece in half and flip one of the cut pieces. Check the fit of the joint.
- Unplug the router.
- Adjust the cutter height if necessary to make the surfaces flush. If the piece that was flipped is higher than the piece that is face up you need to lower the bit. If the flipped piece is lower you need to raise the bit.
- Before plugging the router in be sure that the bit rotates freely and does not contact any part of the router, the router table or the router fence. Plug in the router and make another test cut.

### Create Glue Joint Edges

- Label the best surface of each board as "Face"
- Run one edge of a board with the side labeled "Face" up
- Flip the board and run the opposite edge with the "Face" down.
- Repeat these steps on all but two of the pieces.
- One of the remaining two pieces should be run "Face" side up on one edge only.
- The last should piece be run with the "Face" side down on one edge only.

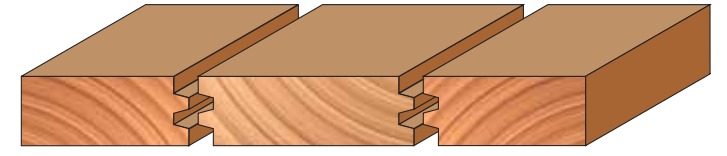

### Glue and Clamp the Panel

- Turn all of the pieces face side up.
- Arrange the pieces so that the mating edges are adjacent and the board on each end has a flat edge.
- Apply glue to all edges and use plenty of clamps to secure the panel until the glue dries.
- Remove the clamps, sand or plane the panel flat and smooth and trim to final size.

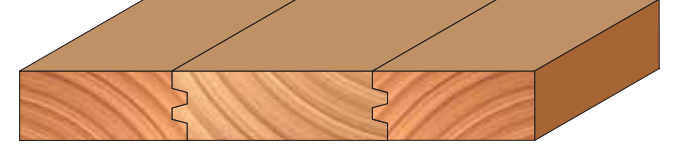

### Optional Add-On Cutters for Expanded Possibilities

#### Add-On Double Sided Profile Cutters

##### Rail Bit Adjustment for Double Sided Doors (K):

- With the router unplugged, install the rail bit in the router.
- Use the spanner wrench (supplied) to remove the upper cutter, bearing and spindle assembly. Store this assembly safely for future use.
- Carefully thread the Long Spindle, Bearing and Cutter into the lower portion of the bit. Tighten this spindle using a closed end or adjustable wrench (not included).

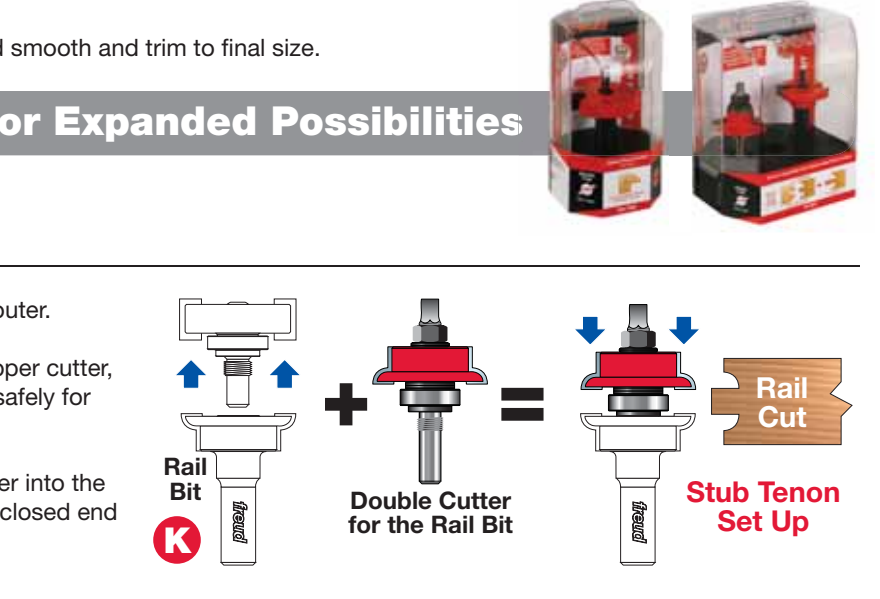

- Use the bearing to position the fence. Adjust the height of the bit so the stub tenon will be centered in the rail.
- Plug the router in, make test cuts in scrap stock to check the bit height. Unplug and adjust the bit if needed.
- Use a backer board, miter gauge, or a coping sled to rout the rail profile with stub tenon on the ends of all rails.

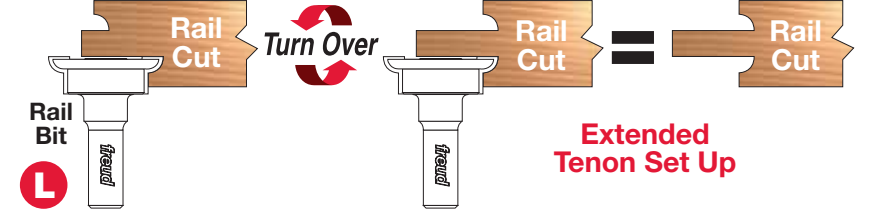

**NOTE:** to produce extended tenons (L), first refer to the instructions for your Premier Adjustable Rail & Stile set, then review these additional procedures. Use your closed end or adjustable wrench to remove the spindle/bearing/cutter assembly. Make cuts with the lower cutter in increments of not more than 1/2". Make cuts with the rail face down first, then turn the rail over and make an identical cut on the back side. In this way the decorative profile will appear on both sides, and the long tenon will be perfectly centered. (Note: the straight cutter supplied with the rail bit is not used in this operation, because the decorative profile is used on both sides of the rail)

##### Stile Bit Adjustment (M):

- With the router unplugged, install the stile bit in the router.
- Use your 1/2" open end or adjustable wrench to remove the nut from the spindle.
- Carefully remove extra shims, bearing, and the small spacer between the bearing and the upper slot cutter.
- Place the Profile Cutter on the bit. BE SURE that you have selected the cutter for the stile bit – the cutting edge must face in the same direction as the lower profile cutter!
- Place the bearing on top of the upper cutter, place at least one shim on top of the bearing, replace the nut and tighten.
- Do not use the 7/16" long spacer – store it safely for future use.
- Use the bearing to align the fence. NOTE: in this application the bearing is for fence alignment purposes only. Your workpiece will not touch the bearing. Like all operations with this set, a router table fence must be used.
- Adjust the height of the bit to match the tenons routed with the stile bit. Plug the router in, and make test cuts in scrap material to check the fit.

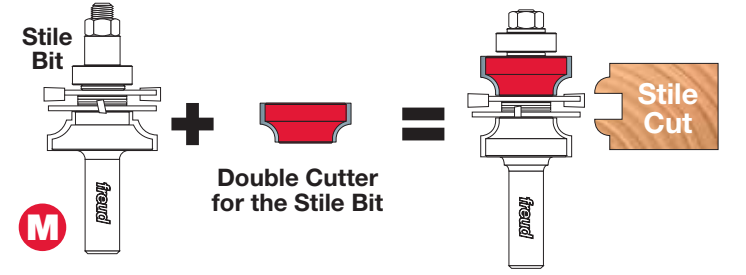

#### Add-On Glass/Screen Panel Cutter

##### Stile Bit Adjustment with Glass/Screen Cutter (N):

- With the router unplugged, install the stile bit in the router. Use your 1/2" open end or adjustable wrench to remove the nut from the spindle.
- Carefully remove extra shims and bearing. Leave the 1.5mm (.06") thick spacer on the top of the upper slot cutter.
- Place the Straight Cutter on the bit. BE SURE that the cutting edge faces in the same direction as the lower cutter!
- Place a shim on top of the straight cutter, then replace the bearing, extra shims and nut. Secure the nut.
- Do not use the 7/16" long spacer – store it safely for future use.
- Use the bearing to align the fence. NOTE: in this application the bearing is for fence alignment purposes only. Your workpiece will not touch the bearing. Like all operations with this set, a router table fence must be used.
- Adjust the height of the bit to match the profile routed with the stile bit. Plug the router in, and make test cuts in scrap material to check the fit.
- Due to the large amount of stock removed, make this cut in 2 or more passes.

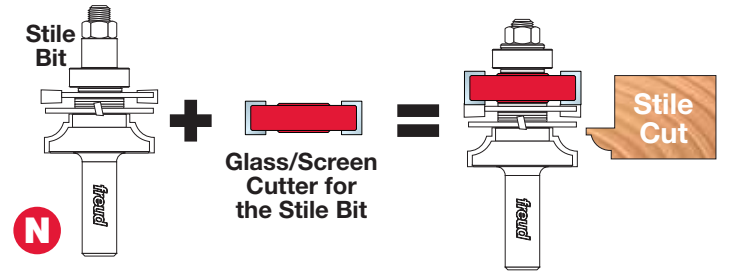

**Just Some of the Other Great Door Making Sets Offered by Freud:**



To learn more, please visit:  
[www.mcfelys.com](http://www.mcfelys.com)  
1-800-443-7937



**freud**  
Precisely the best.